



## ADDITIONAL ACCESSORIES FROM LEM

ITEM	SKU#
The Original Jerky Cannon	468
LEM Jerky Gun	555
Backwoods Jerky Variety Pack	156
Jerky Board and Knife	616



### ATTENTION

If any components of this unit are broken,  
or if the unit does not operate properly,  
please contact LEM Products at

**1-877-536-7763**

For more great products, log onto [www.lemproducts.com](http://www.lemproducts.com)

# DEHYDRATOR WITH DIGITAL TIMER

5 Tray MODEL #1009 120V 60HZ 550W  
10 Tray MODEL #1010 120V 60HZ 800W



**LEM Products**  
**109 May Drive**  
**Harrison, OH 45030**  
**Toll Free: 1-877-536-7763**  
**[www.lemproducts.com](http://www.lemproducts.com)**

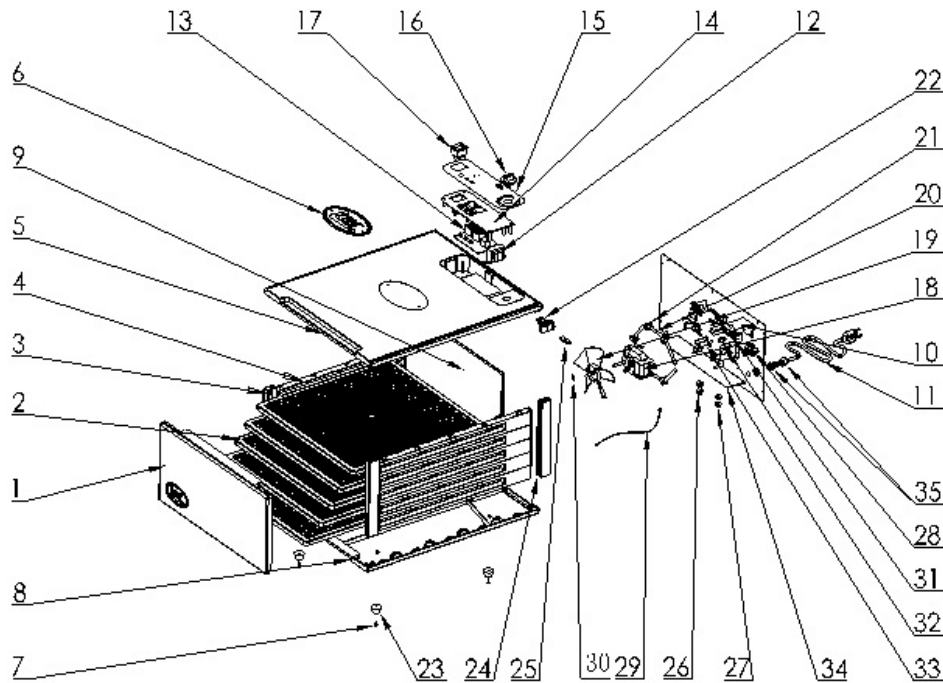

#	DESCRIPTION	QTY	#	DESCRIPTION	QTY
1	Door	1	19	Fan	1
2	Tray	5/10	20	Heating Coil	1
3	Front Corner Frame	2	21	Ceramic Blocks for Heating Coil	5
4	Side Board	2	22	Temperature Regulator	1
5	Top Board	1	23	Rubber Feet	4
6	Logo Plate	1	24	Rear Corner Frame	2
7	Screw for Rubber Feet	4	25	Plastic Fixed Block	1
8	Bottom Board	1	26	Ceramic Pin	2
9	Wire Partition	1	27	Ceramic Carrier	2
10	Rear Board Assembly	1	28	6 Wire Electric Block	1
11	Electric Cord	1	29	Ground Wire	1
12	Transformer	1	30	Fan Clip	1
13	Control Circuit Board	1	31	Fuse Fixed Block	1
14	Cover of Circuit	1	32	Fuse Fixed Piece	1
15	Label of Control Board	1	33	Motor Bracket	2
16	Knob	1	34	Apron	1
17	Switch	1	35	Cord Clip	1
18	Motor	1			

**IMPORTANT WARRANTY INFORMATION BELOW:  
PLEASE READ, FILL OUT AND RETURN ENCLOSED  
WARRANTY CARD TO ENSURE WARRANTY COVERAGE.  
THIS WARRANTY COVERS THE LEM PRODUCTS**

**5 Tray Dehydrator OR 10 Tray Dehydrator**

**THE WARRANTY IS EXTENDED TO THE ORIGINAL PURCHASER ONLY.**

**WARRANTY DURATION:** This product is warranted to the original purchaser for a period of one (1) year from the original purchase date. **EACH UNIT COMES WITH A WARRANTY CARD, WHICH MUST BE FILLED OUT COMPLETELY AND RETURNED IMMEDIATELY, WITH A COPY OF THE PURCHASING RECEIPT. FAILURE TO RETURN YOUR WARRANTY CARD WILL LIMIT WARRANTY TO 90 DAYS WITH PROOF OF PURCHASE.**

**WARRANTY COVERAGE:** This product is warranted against defective materials or workmanship. The warranty is void if the product has been damaged by accident, misuse, neglect, modification or improper service or repairs by unauthorized personnel. It is also void if damaged in shipment or by other causes not arising out of defects in the materials or workmanship. This warranty does not extend to any units which have been in violation of written instructions furnished, or to units which have been altered or modified.

**WARRANTY DISCLAIMERS:** This warranty is in lieu of all warranties expressed or implied, and no representative or person is authorized to assume any other liability in connection with the sale of our products. There shall be no claims for defects or failure of performance under any theory of sort, contract or commercial law including, but not limited to negligence, gross negligence, strict liability or breach of contract.

The manufacturer declines all responsibility for damage to persons, things or animals arising from the failure to comply with the norms contained in this manual. The manufacturer reserves the right to make modifications at anytime to the models while maintaining the main characteristics described herein. The manufacturer also declines all responsibility for any errors in compiling this manual.

**WARRANTY PERFORMANCE:** During the above one year warranty period, a product with a defect will either be repaired or replaced after the product has been inspected by an LEM Service Technician. **NO PRODUCT WILL BE EVALUATED UNLESS THE ORIGINAL SALES RECEIPT OR THE WARRANTY CARD IS ON FILE.** The repaired product will be in warranty for the balance of the one year warranty period. No charge will be made for such repair or replacement.

**IMPORTANT NOTICE:** If any parts are missing or defective, please contact our Customer Service Department for assistance at 877-536-7763. (M-F 8:30am to 4:30pm EST) **DO NOT RETURN TO THE STORE WHERE THE ITEM WAS PURCHASED.**

**LEM PRODUCTS MERCHANDISE RETURN POLICY WARRANTY SERVICE:**

To obtain service under terms of this warranty, please contact us at 877-536-7763 to obtain authorization prior to returning the merchandise. No merchandise will be accepted without prior authorization. Please return the product pre-paid in the original packaging if possible, enclose a copy of your receipt, (keep a copy of your proof-of purchase for your records) and include a written explanation of the issue. Ship to LEM Products, 107 May Drive, Harrison, OH 45030, LEM Products is not responsible for damage incurred in shipping, make certain to pack product properly. Return shipping charges are the responsibility of the purchaser. Packages returned to LEM should be insured for the value of the product to cover any damages that may occur during shipping.



## REVIEWING THE DEHYDRATING PROCESS

To obtain the best results:

1. Choose high quality foods. Do not use foods with bruises or blemishes.
2. Wash food, use clean utensils and keep work area clean.
3. Pre-treat foods to prevent discoloration.
4. Always use lean meats. Remove as much fat as possible prior to dehydrating.
5. Do not overlap foods. Lay foods flat on the Dehydrating Trays.
6. If uneven drying is noticed, rotate shelves 180°
7. Check dryness every 2 hours until crisp, pliable or leathery depending on the product.
8. Cool food before testing for dryness.
9. Proper storage is essential to maintain the quality of the food. Vacuum sealing is ideal for keeping dried foods.

## MAKING JERKY

Meat being used for jerky should be as lean as possible. Using lean meat will help the meat dry faster. Ground meat should be 79%-90% lean. Ground turkey, venison, buffalo and elk are other excellent choices for jerky.

Jerky seasonings are available for all tastes (*available at lemproducts.com*). Whenever jerky is being made, cure (sodium nitrite) (*available at lemproducts.com*) should be used. Cure is used to help prevent botulism during drying at low temperatures. Follow the manufactures directions on the cure packet.

Marinate meats in the refrigerator. Do not leave meats unrefrigerated. Always wash hands thoroughly with soap and water prior to and after working with meat products.

Special consideration must be made when using venison or other wild game, as it can become heavily contaminated during field dressing. Venison is often held at temperatures that could potentially allow bacteria to grow, such as when it is being transported. Refer to the USDA Meat and Poultry Department for further information on meat and food safety.

When using a dehydrator, check the temperature of the dehydrator with a dial thermometer (*available at lemproducts.com*) before drying jerky. The minimum recommended temperature for drying meats is 145° F. **IMPORTANT:** Before you place the meat in a dehydrator, it is highly recommended to heat the meat to 160°F (poultry to 165°F) BEFORE the dehydrating process. This step assures that any bacteria present will be destroyed by heat. After heating to 160° F, maintaining a constant dehydrator temperature of 130-140° F during the drying process is important because: 1) the process must be fast enough to dry food before it spoils; and 2) it must remove enough water so the microorganisms are unable to grow.

If you are using a marinade, shake off excess liquid before placing the meat in evenly spaced single layers approximately ¼" apart on the racks.

Dry meat at 145-150° F for 4-7 hours. You may need to blot fat droplets from the surface of the meat occasionally, using a paper towel. Drying times may vary based on many circumstances including but not limited to: the relative humidity of the room, the temperature of the meat at the beginning of the drying process, the amount of meat in the dehydrator, leanness of meat, etc.

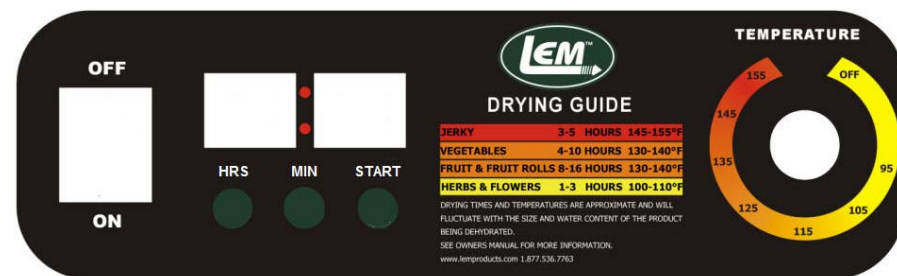

## OPERATING INSTRUCTIONS

### IT IS IMPORTANT TO READ AND UNDERSTAND ALL OF THE INSTRUCTIONS

1. Make sure power switch is turned off. Place the unit on a clean, dry surface away from children and pets. Plug into an undamaged grounded electrical outlet.
2. Follow your recipe for the food that you wish to dehydrate then place the food evenly on the shelves provided. You can use cooking spray to help prevent sticking. Do not allow food pieces to touch.
3. Place shelves into the dehydrator.
4. Slide door into place.
5. Turn the temperature knob to the desired temperature.
6. Turn on the dehydrator and the LED control board will show "00:00".
7. Press button "HRS" to set the hour time, hour increases by 1 each time, and the LED will blink. The maximum hour time is 30.
8. Press button "MIN" to set the minute time, minutes increase by 5 each time, and the LED will blink. The maximum minute time is 55.
9. Press "START" to turn on the unit.
10. The timing shown on the LED board will countdown and the machine will shut off automatically when time has elapsed.
11. If it is necessary to stop the unit before time has elapsed simply push the "START" button and the dehydrator will shut off. If drying appears to be uneven you may want to rotate shelves 180°. Use oven mitts, shelves will be hot.
12. If you would like to resume the dehydrating process simply push the "START" button again and the dehydrator will resume heating and time countdown.
13. When dehydrating is complete, use oven mitts to remove the door and set it on a heat resistant surface. Slide shelves out and remove finished product.
14. Allow dehydrator to cool completely prior to clean up.
15. Set power switch to "off" position and disconnect the electrical cord from outlet.
16. Wipe with a clean damp cloth. Do not immerse the dehydrator in water.
17. Wash dehydrator trays with warm soapy water. Rinse and hand dry.

## IMPORTANT SAFEGUARDS

When using electrical appliances, basic safety precautions should always be followed including the following:

1. Read all instructions before using.
2. Do not touch the hot surfaces. Use handles or knobs.
3. To protect against electrical shock and affecting the function, do not immerse the appliance, body, cord, or plug in water or other liquid.
4. Close supervision is necessary when any appliance is used by or near children.
5. Unplug from outlet when not in use and before cleaning. Allow to cool before putting on or taking off parts, and before cleaning the appliance.
6. Do not operate it with a damaged cord or plug or after the appliance malfunctions or has been damaged in any manner. Return the appliance to the nearest authorized service facility for examination, repair or adjustment.
7. The use of accessory attachments are not recommended by the appliance manufacturer and may result in fire, electric shock or injuries.
8. Do not use outdoors.
9. Do not let cord hang over edge of table or counter, or touch hot surfaces.
10. Do not place the appliance on or near a hot gas or electric burner, or in a heated oven.
11. Do not move the appliance when the appliance contains food.
12. Do not use the appliance for other than intended use.
13. To disconnect, turn the knob to "OFF", then remove plug from wall outlet.
14. CAUTION: to ensure continued protection against risk of electric shock, connect to properly grounded outlets only when the appliance is provided with a flexible cord less than 4-1/2 feet (1.4m) in length, the extension cord should be a grounding-type 3-wire cord and meet the following requirements:
  - 1) a short power-supply cord should be used to reduce the risk resulting from becoming entangled in or tripping over a longer cord.
  - 2) longer extension cords may be used if care is exercised in their use.
  - 3) If a longer extension cord is used
    - a) the marked electrical rating of the extension cord should be as great as the electrical rating of the appliance
    - b) the cord should be arranged so that it will not drape over the countertop or tabletop where it can be pulled on by children or tripped over unintentionally.

**This appliance is intended for Household Use Only.**

**SAVE THESE INSTRUCTIONS.**

## GUARDE DE SECURITE IMPRTANTE

**Lors de l'utilisation des appareils électriques, des précautions de sécurité de base devraient toujours être suivies y compris ce qui suit:**

1. lire toutes les instructions avant d'utiliser.
  2. Ne pas toucher les surfaces chaudes. Utilisez les poignées ou des boutons.
  3. Pour protéger contre les chocs électriques et affectant la fonction, ne pas plonger l'appareil, le corps, le cordon, ou branchez dans l'eau ou autres liquides.
  4. Proche surveillance est nécessaire lorsque tout appareil est utilisé par ou près des enfants.
  5. Débrancher de sortie lorsque ne s'en servent pas et avant le nettoyage. Permettre à refroidir avant enfiler ou décoller de pièces, et avant le nettoyage de l'appareil.
  6. Ne fonctionnent pas avec un cordon endommagé ou fiche ou après les défaillances de l'appareil ou a été endommagé en aucune manière. Retour de l'appareil au service autorisée le plus proche pour l'examen, de réparation ou de réglage.
  7. L'utilisation d'accessoires pièces jointes ne pas recommandé par le fabricant de l'appareil peut entraîner en feu, les chocs électriques ou les blessures.
  8. Ne pas utiliser à l'extérieur.
  9. Ne laissez pas de cordon surplombent à bord de table de compteur, ou toucher des surfaces chaudes.
  10. Ne placez pas l'appareil sur ou près d'un gaz chaud ou brûleur électrique ou dans un four chauffé.
  11. Ne pas déplacer l'appareil lorsque l'appareil est contenu avec de la nourriture.
  12. Ne pas utiliser l'appareil pour autres que l'utilisation prévue.
  13. Pour se déconnecter, tourner le bouton « Off », puis retirez le fiche par débouche murale.
  14. Attention: afin d'assurer le maintien de la protection contre le risque de choc électrique, se connecter proprement aux sorties a la terre seulement Lorsque l'appareil fourni avec un flexible du cordon moins de 4-1/2 pieds (1,4 m) de longueur, la rallonge électrique doit être un cordon de 3 fils échouement-type et respecter les exigences suivantes:
    - 1) un cordon d'alimentation court devrait servir à réduire les risques résultant de devenir entourée ou faire trébucher sur une plus longue corde.
    - 2) plus longs cordons d'extension sont disponibles et peut-être utilisé si leur utilisation est prudent.
    - 3) Si une rallonge plus longue est utilisée :
- a) la cote électrique marquée de la cordon rallonge électrique doit être aussi grande que la cote électrique de l'appareil
  - b) le cordon devrait être rangé afin qu'il ne sera pas drapé sur le comptoir ou dessus de table où il peut être tiré sur par des enfants ou trébuché sur involontairement.

Cet appareil est destiné aux Ménages Utilisation Seulement.

ENREGISTREZ CES INSTRUCTIONS

## FOOD DRYING GUIDES

The following charts are guidelines for the preparation of various fruits, vegetables and meats. Drying times will vary depending on the room temperature, relative humidity and moisture levels in the food that you are drying. If the moisture level is high, the drying time will be on the high end of the range. Keep in mind that drying times are also affected by the amount of food placed on the shelves. Overloading the shelves will slow the drying time and may produce poor results. When dehydrating foods, it is important to check on the dryness of the product. If the product is not thoroughly dried, mold may form during storage. To test for dryness, remove a piece of food from the dehydrator and allow cooling to room temperature. Bend and tear the piece to check for internal moisture.

**IMPORTANT:** Before you place the meat in a dehydrator, it is highly recommended to heat the meat to 160°F (poultry to 165°F) BEFORE the dehydrating process. This step assures that any bacteria present will be destroyed by heat.

For more information please visit USDA web page:  
[http://www.fsis.usda.gov/Fact\\_Sheets/Jerky\\_and\\_Food\\_Safety/index.asp](http://www.fsis.usda.gov/Fact_Sheets/Jerky_and_Food_Safety/index.asp).

Food Drying Guide, Vegetables at 125°F			
FOOD	PREPARATION	TEST	TIME
Asparagus	Wash & cut into 1" pieces.	Crunchy	4-6 hrs.
Beans, Green or Waxed	Wash; remove ends, cut into 1" pieces.	Crunchy	9-12 hrs.
Beets	Remove all but ½" of the top, scrub thoroughly, steam blanch until tender. Peel and cut into ¼" thick slices.	Pliable	9-12 hrs.
Broccoli	Wash & trim. Cut stems into ¼" pieces. Dry florets whole.	Crunchy	10-14 hrs.
Cabbage	Wash & trim. Cut into 1/8" slices	Crunchy	8-11 hrs.
Carrots	Wash & trim tops. Peel or scrape if desired. Cut into 1/8" slices.	Pliable	7-11 hrs.
Celery	Wash. Separate leaves and stalks. Cut stalks into ¼" strips.	Crunchy	3-10 hrs.
Corn	Shuck corn and remove silk. Steam until corn milk is set. Cut kernels from cob and spread on plastic screen. Stir several times during drying.	Crunchy	7-10 hrs.
Cucumber	Wash & trim. Cut into 1/8" slices.	Pliable	4-8 hrs.
Eggplant	Wash & peel. Cut into ¼" slices.	Pliable	4-8 hrs.
Mushroom	Wash & cut into 3/8" slices.	Pliable	4-7 hrs.
Parsnips	Scrub thoroughly, steam blanch until tender. Peel if desired and cut into 3/8" thick slices.	Pliable/ Tough	7-11 hrs.
Peppers	Wash and remove stems, seeds and white section. Pat dry. Cut into ¼" thick strips or rings.	Pliable	4-8 hrs.
Potatoes	Use New potatoes. Wash. Peel if desired. Steam blanch 4-6 minutes.	Crunchy /Pliable	7-13 hrs.
Summer Squash	Wash & peel. Cut into ¼" slices.	Pliable	10-14 hrs.
Tomatoes	Wash and remove stems. Slice into ¼" circles. For cherry tomatoes, slice in half, dry skin side down.	Pliable	5-9 hrs.
Zucchini	Wash. Peel if desired. Cut onto 1/8" slices or chips.	Crunchy	7-11 hrs.
Food Drying Guide, Fruits at 135° F			
Apples	Wash, core and peel if desired. Cut into ¼" slices. Dust with cinnamon if desired.	Pliable	7-15 hrs.
Apricots	Wash, halve and remove pit. Slice if desired and dry skin side down.	Pliable	21-29 hrs.
Bananas	Wash, peel and slice into 1/8" slices	Pliable	7-10 hrs.
Figs	Wash. Cut out blemishes, quarter. Dry skin side down.	Pliable	22-30 hrs.
Kiwi	Wash, peel and slice into ¼" slices	Crisp	8-15 hrs.
Nectarines	Wash, halve and remove pit. Slice into 3/8" slices and dry skin side down.	Pliable	8-17 hrs.
Peaches	Wash, halve and remove pit. Slice into ¼" slices and dry skin side down.	Pliable	8-16 hrs.
Pears	Wash, core and peel if desired. Cut into ¼" slices or quarter.	Pliable	8-16 hrs.
Pineapple	Peel, remove fibrous eyes, remove core. Cut into ¼" slices or wedges.	Pliable	11-18 hrs.
Rhubarb	Wash, cut into 1" lengths.	Pliable	6-10 hrs.
Strawberries	Wash, cut out caps, slice ¼" thick.	Crisp	7-15 hrs.
Watermelon	Cut off rind, cut into wedges and remove seeds.	Pliable & Sticky	8-10 hrs.
Food Drying Guide, Jerky at 145°-150°F			
Jerky	Use lean meat and remove as much fat as possible. Cut uniform ¼" thick or less slices. Do not overlap slices on the shelves.	Pliable	3-4 hrs. Meat temp. should reach 145°-150°F